

Title			
DFdsPIC804A			
Size	Document Number	Connectors	Rev
B			0.2
Date:	Friday, February 13, 2009	Sheet	1 of 5

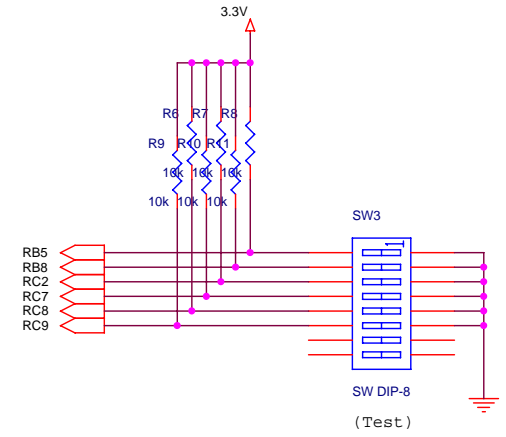

Title		
DFdsPIC804A		
Size	Document Number	Rev
B	dsPIC and Peripherals	0.2
Date:	Friday, February 13, 2009	Sheet 2 of 5

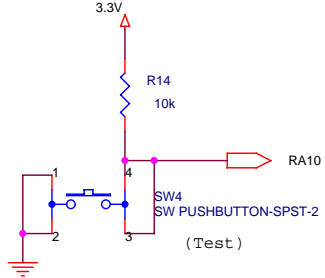
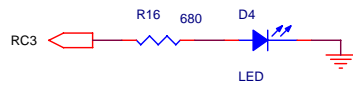
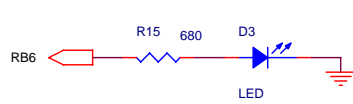
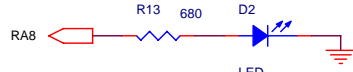
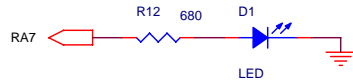
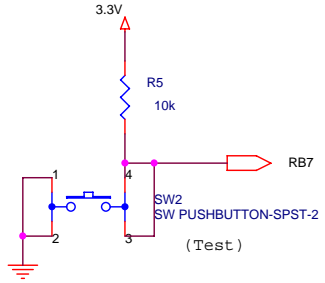
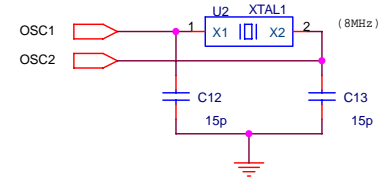
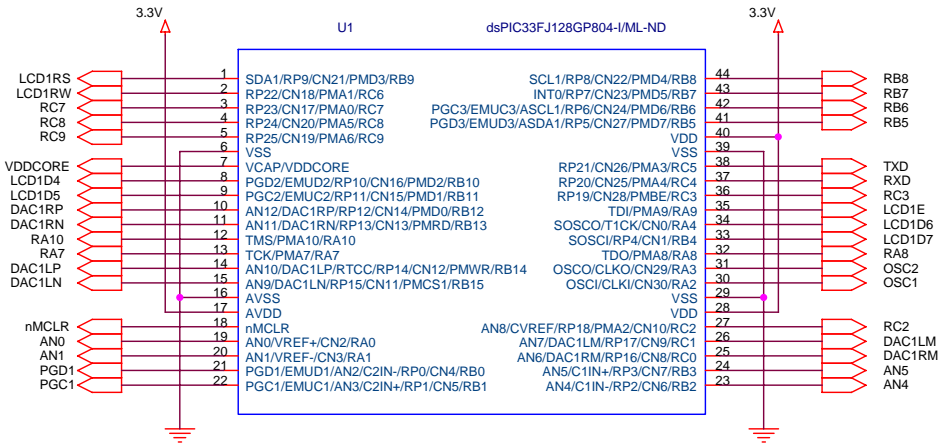
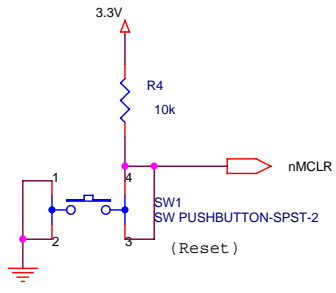
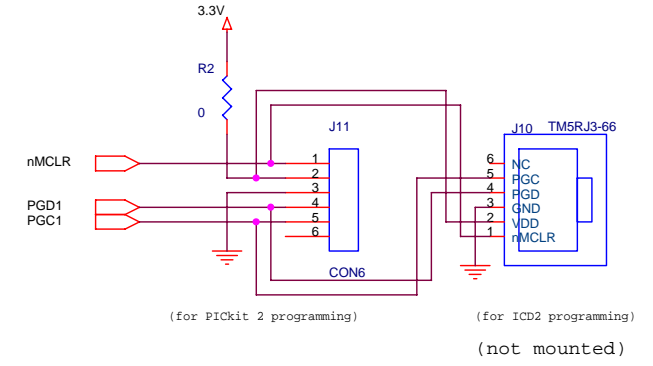
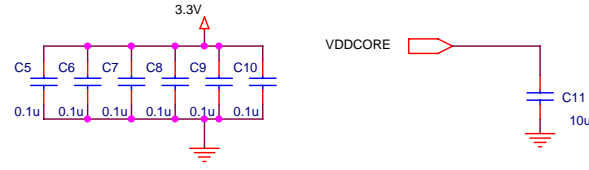
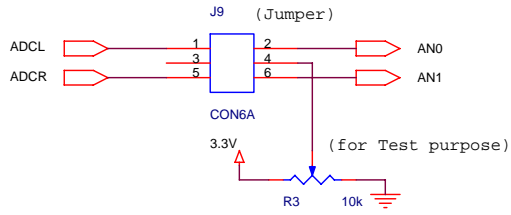
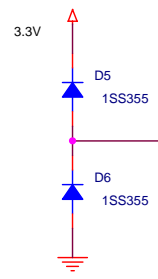
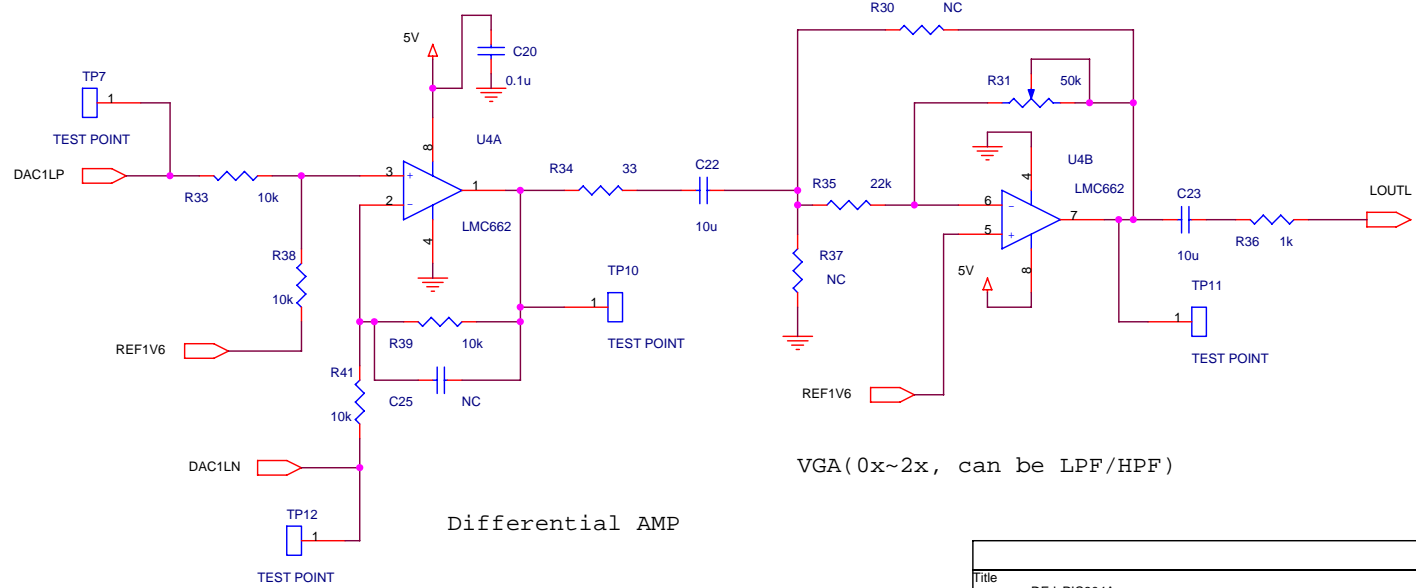
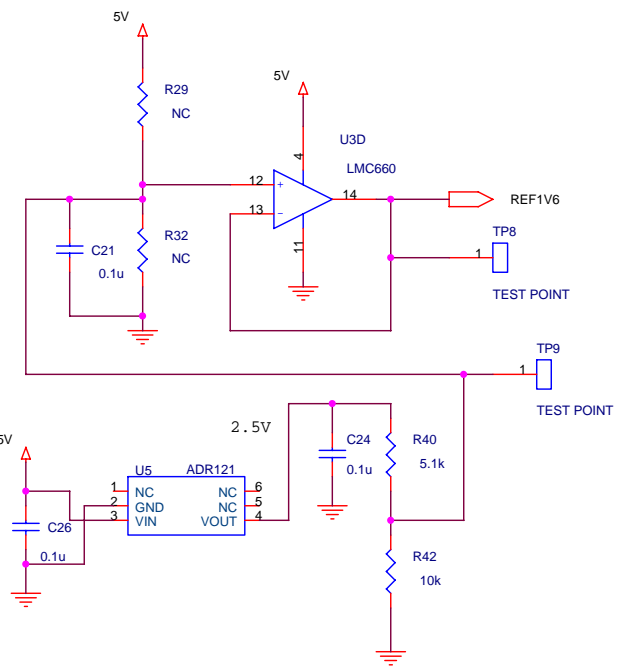
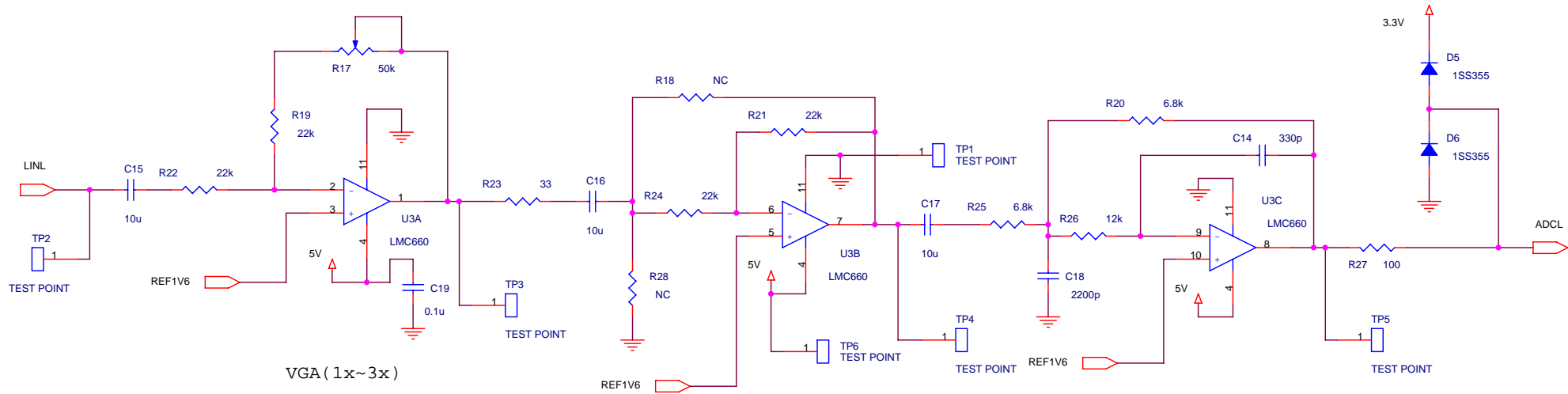

Title		
DFdsPIC804A		
Size	Document Number	Rev
B	OP AMPs (Lch)	0.2
Date:	Friday, February 13, 2009	Sheet 3 of 5

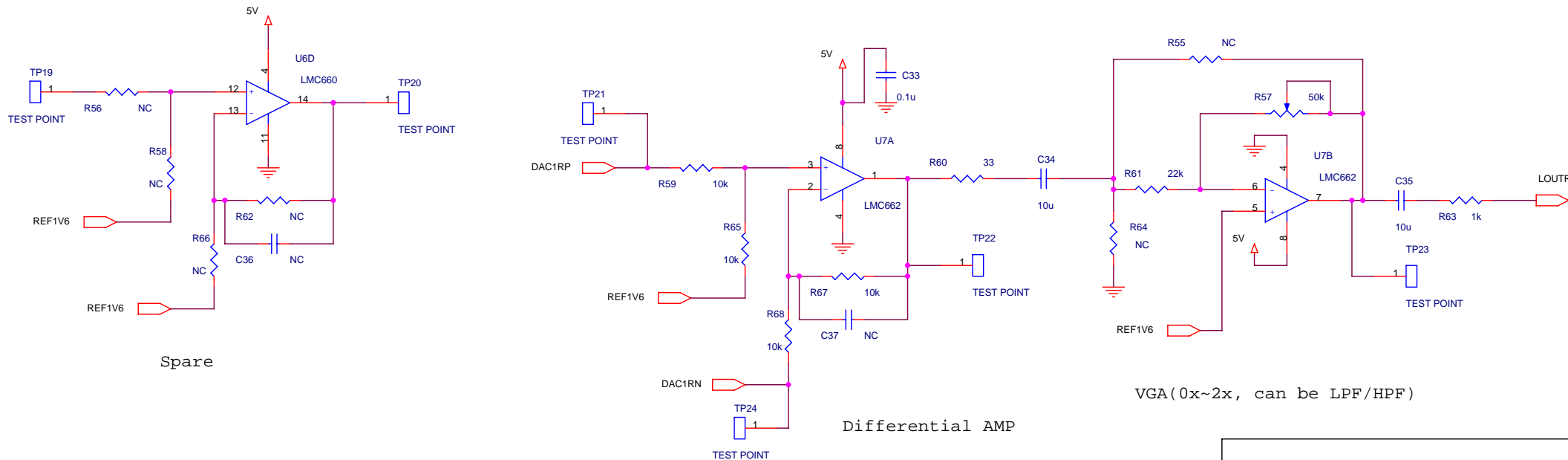
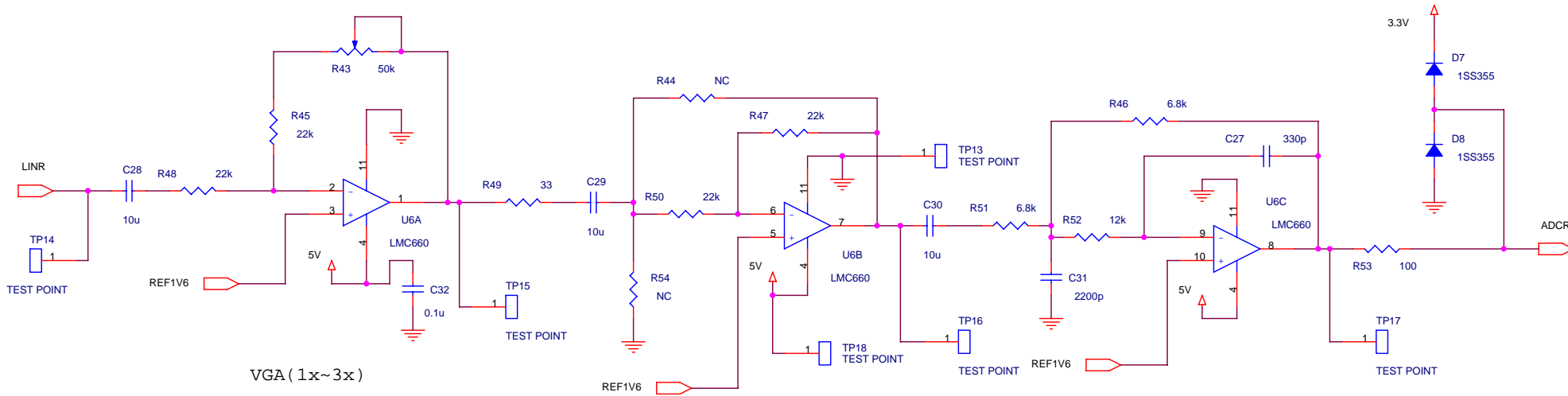

Title		
DFdsPIC804A		
Size	Document Number	Rev
B	OP AMPs (Rch)	0.2
Date:	Friday, February 13, 2009	Sheet 4 of 5

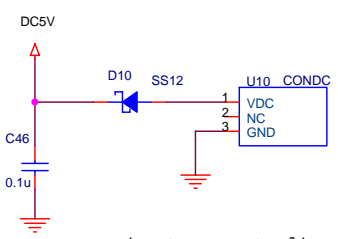
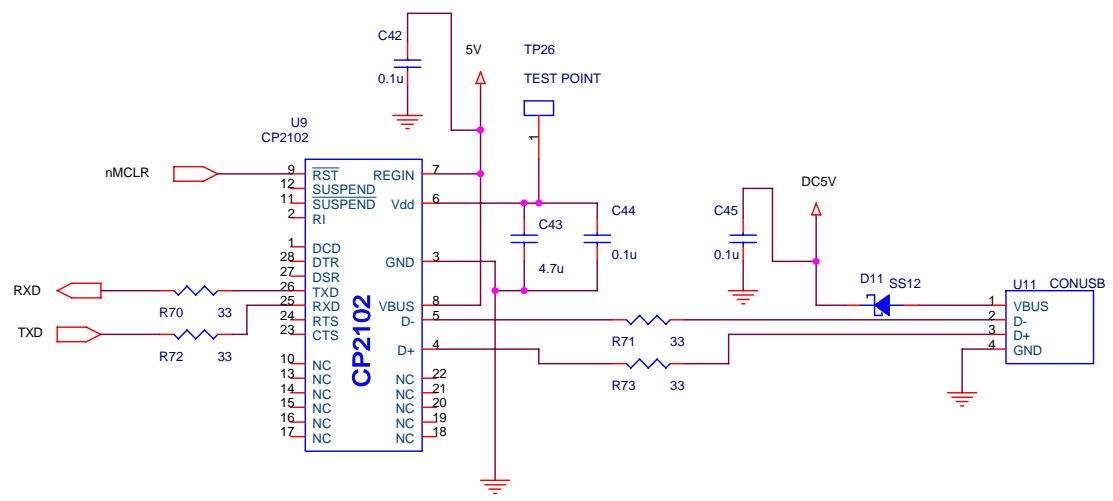
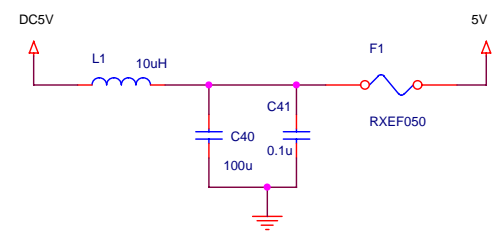
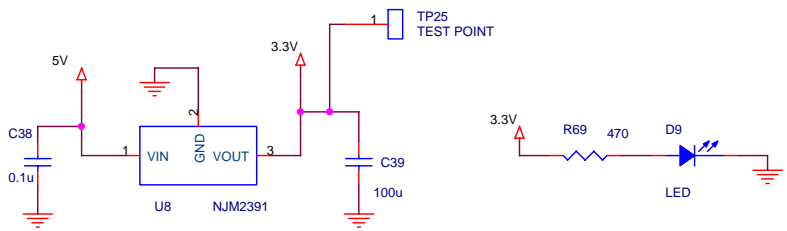

Title		
DFdsPIC804A		
Size	Document Number	Rev
B	Power Supply & USB	0.2
Date:	Friday, February 13, 2009	Sheet 5 of 5